

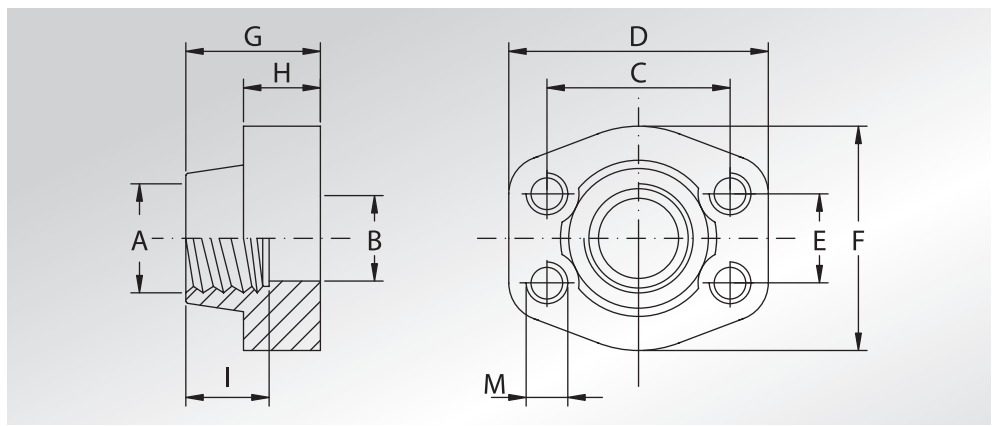

CONTROFLANGE FILETTATE GAS

BSP THREADED COUNTER-FLANGES



Pressione max di esercizio raccomandata Kg/cm ²	Grandezza	Tipo	Dimensioni										Peso Kg
Maximum recommended working pressure Kg/cm ²	Size	Type	Dimensions										Weight Kg
			A	B	C	D	E	F	G	H	I	M	

SERIE 3000

													Metric	Unc	
345	1/2"	GFS080G	1/2" GAS	13	38,10	57	17,48	46	36	16	19	M8	5/16"	0,26	
345	1/2"	GFS080G038	3/8" GAS	13	38,10	57	17,48	46	36	16	19	M8	5/16"	0,28	
345	3/4"	GFS100G	3/4" GAS	19	47,63	65	22,23	50	36	18	19	M10	3/8"	0,41	
345	3/4"	GFS100G012	1/2" GAS	13	47,63	65	22,23	50	36	18	19	M10	3/8"	0,44	
345	1"	GFS102G	1" GAS	25	52,37	70	26,19	55	38	18	22	M10	3/8"	0,49	
345	1"	GFS102G034	3/4" GAS	19	52,37	70	26,19	55	35	21	19	M10	3/8"	0,55	
276	1"1/4	GFS104G	1"1/4 GAS	32	58,72	79	30,18	68	41	21	22	M10	7/16"	0,71	
276	1"1/4	GFS104G100	1" GAS	25	58,72	81	30,18	65	42	25	22	M10	7/16"	0,85	
207	1"1/2	GFS106G	1"1/2 GAS	38	69,85	93	35,71	78	45	25	24	M12	1/2"	1,12	
207	1"1/2	GFS106G114	1"1/4 GAS	32	69,85	95	35,71	78	45	27	22	M12	1/2"	1,24	
207	2"	GFS108G	2" GAS	51	77,77	102	42,88	90	45	25	30	M12	1/2"	1,24	
207	2"	GFS108G112	1"1/2 GAS	38	77,77	102	42,88	90	45	25	24	M12	1/2"	1,59	
172	2"1/2	GFS110G	2"1/2 GAS	63	88,90	114	50,80	105	50	25	30	M12	1/2"	1,66	
173	2"1/2	GFS110G200	2" GAS	51	88,90	114	50,80	105	50	25	30	M12	1/2"	2,20	
138	3"	GFS112G	3" GAS	73	106,38	134	61,93	124	50	27	34	M16	5/8"	2,37	
138	3"	GFS112G212	2"1/2 GAS	63	106,38	134	61,93	124	50	27	30	M16	5/8"	2,65	
34	3"1/2	GFS114G	3"1/2 GAS	89	120,65	152	69,85	136	48	27	34	M16	5/8"	2,51	
34	3"1/2	GFS114G300	3" GAS	73	120,65	152	69,85	136	48	27	34	M16	5/8"	3,37	
34	4"	GFS116G	4" GAS	99	130,18	162	77,77	146	48	27	34	M16	5/8"	2,87	
34	4"	GFS116G312	3"1/2 GAS	89	130,18	162	77,77	146	48	27	34	M16	5/8"	3,39	
34	5"	GFS118G	5" GAS	120	152,40	184	92,08	180	50	28	30	M16	5/8"	5,80	

SERIE 6000

414	1/2"	GFS401G012	1/2" GAS	13	40,49	57	18,24	46	36	16	19	M8	5/16"	0,26
414	1/2"	GFS401G038	3/8" GAS	13	40,49	57	18,24	46	36	16	19	M8	5/16"	0,29
414	3/4"	GFS402G	3/4" GAS	19	50,80	71	23,80	55	35	21	22	M10	3/8"	0,55
414	3/4"	GFS402G012	1/2" GAS	13	50,80	71	23,80	55	35	21	19	M10	3/8"	0,60
414	1"	GFS403G	1" GAS	25	57,15	81	27,76	65	42	25	24	M12	7/16"	0,87
414	1"	GFS403G034	3/4" GAS	19	57,15	81	27,76	65	42	25	22	M12	7/16"	0,9
414	1"1/4	GFS404G	1"1/4 GAS	32	66,68	95	31,75	78	45	27	25	M14	1/2"	1,21
414	1"1/4	GFS404G100	1" GAS	25	66,68	95	31,75	78	45	27	24	M14	1/2"	1,34
414	1"1/2	GFS405G	1"1/2 GAS	38	79,38	112	36,50	94	50	30	28	M16	5/8"	1,90
414	1"1/2	GFS405G114	1"1/4 GAS	32	79,38	112	36,50	94	50	30	25	M16	5/8"	2,03
414	2"	GFS406G	2" GAS	51	96,82	134	44,45	114	65	37	30	M20	3/4"	3,43
414	2"	GFS406G112	1"1/2 GAS	38	96,82	134	44,45	114	65	37	28	M20	3/4"	3,92
414	2"1/2	GFS507G	2"1/2 GAS	63	123,80	180	58,70	152	80	45	35	M24	7/8"	7,25
414	3"	GFS508G	3" GAS	73	152,40	208	71,40	178	90	55	40	M30	1"1/8	11,8

DESIGNAZIONE PER ORDINE DESIGNATION FOR ORDER	Materiale / Material	
	S355	AISI 316L
Controflangia con fori di fissaggio filettati metrici Counter-flange with metric threaded fixing holes	GFS...G	GFX...G
Controflangia con fori di fissaggio filettati unc Counter-flange with unc threaded fixing holes	GFS...GU	GFX...GU