

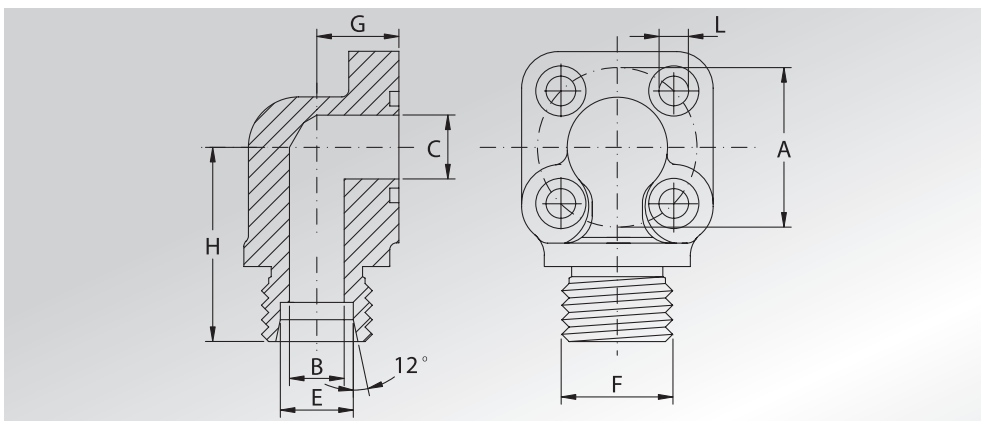

**RACCORDI
A 4 FORI A 90°
FILETTATI METRICI
DIN 3901 - 3902**

**DIN 3901 - 3902
METRIC THREADED 90°
CONNECTORS
WITH 4 FIXING HOLES**



Pressione max di esercizio raccomandata Kg/cm ²	Interasse	Tipo	Dimensioni								Viti metriche	Or tipo	Peso Kg
Maximum recommended working pressure Kg/cm ²	Distance between the holes	Type	Dimensions								Metric screws	Or type	Weight Kg
			A	B	C	E	F	G	H	L			
300	35	GF3590M16	35	8	13	10	M16x1,5	18	41,5	6,4	N.2 M6x35 N.2 M6x20	3075	0,15
300	35	GF3590M18	35	10	13	12	M18x1,5	18	41,5	6,4	N.2 M6x35 N.2 M6x20	3075	0,18
250	35	GF3590M22	35	12	13	15	M22x1,5	18	41,5	6,4	N.2 M6x35 N.2 M6x20	3075	0,20
250	35	GF3590M24	35	12	13	16	M24x1,5	18	41,5	6,4	N.2 M6x35 N.2 M6x20	3075	0,22
250	35	GF3590M26	35	12	13	18	M26x1,5	18	41,5	6,4	N.2 M6x35 N.2 M6x20	3075	0,24
100	40	GF4090M22	40	12	19	15	M22x1,5	24	41,5	6,4	N.2 M6x45 N.2 M6x25	3100	0,18
100	40	GF4090M26	40	15	19	18	M26x1,5	24	41,5	6,4	N.2 M6x45 N.2 M6x25	3100	0,20
100	40	GF4090M30	40	17	19	22	M30x2	24	41,5	6,4	N.2 M6x45 N.2 M6x25	3100	0,25

**DESIGNAZIONE PER ORDINE
DESIGNATION FOR ORDER**

Solo raccordo
Only connector

Raccordo con viti metriche, grower e o-ring
Connector with metric screws, grower type washers and o-ring

Materiale / Material

S355

GF..90M...

GF..90M...M

NOTE / NOTES

Rivestimento superficiale: zincatura Cr3
Superficial coating : zinking Cr3