

FLANGE OVALI CON FORO PASSANTE

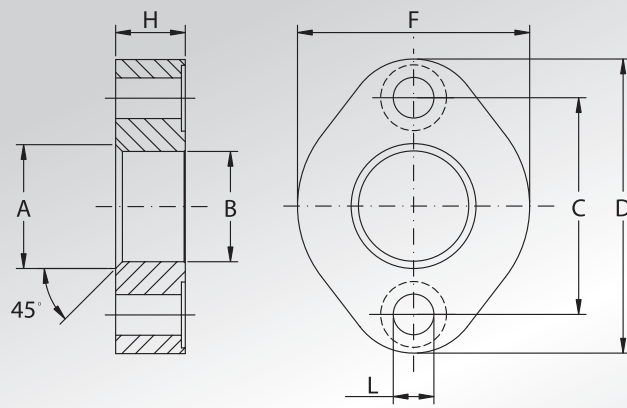

OVAL FLANGES WITH THROUGH HOLE



Pressione max di esercizio raccomandata Kg/cm ²	Grandezza	Tipo	Dimensioni							Peso Kg
Maximum recommended working pressure Kg/cm ²	Size	Type	Dimensions							Weight Kg
			A	B	C	D	F	H	L	

SERIE 6000

414	1/2"	OVA401A20	22	20,5	44,40	60	48	14	8,5	0,18
414	1/2"	OVA401A23	27	24	44,40	60	48	14	8,5	0,18
414	3/4"	OVA402A27	32	28,5	56,10	76	60	18	10,5	0,34
414	1"	OVA403A37	43	37,5	63,60	88	70	22	12,5	0,52
414	1"1/4	OVA404A44	49	44	73,90	103	78	25	14,5	0,75

DESIGNAZIONE PER ORDINE DESIGNATION FOR ORDER	Materiale / Material S355
--	------------------------------

Solo flangia
Only flange

OVA...A

NOTE / NOTES

Nella fornitura non sono previste viti di fissaggio
In our supply screws are not foreseen