

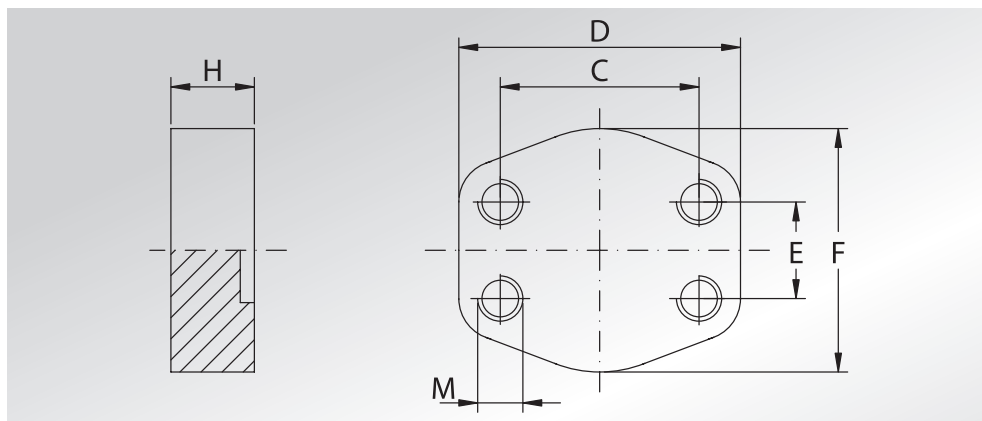

**CONTROFLANGE
CIECHE**

**BLIND
COUNTER-FLANGES**



Pressione max di esercizio raccomandata Kg/cm ²	Grandezza	Tipo	Dimensioni							Peso Kg
Maximum recommended working pressure Kg/cm ²	Size	Type	Dimensions							Weight Kg
			C	D	E	F	H	M		

SERIE 3000

								Metric	Unc	
345	1/2"	GFC080	38,10	56	17,48	46	16	M8	5/16"	0,25
345	3/4"	GFC100	47,63	65	22,23	50	16	M10	3/8"	0,34
345	1"	GFC102	52,37	70	26,19	60	19	M10	3/8"	0,46
276	1"1/4	GFC104	58,72	79	30,18	68	18	M10	7/16"	0,60
207	1"1/2	GFC106	69,85	93	35,71	78	20	M12	1/2"	0,89
207	2"	GFC108	77,77	102	42,88	90	20	M12	1/2"	1,15
172	2"1/2	GFC110	88,90	114	50,80	105	20	M12	1/2"	1,47
138	3"	GFC112	106,38	134	61,93	124	24	M16	5/8"	2,47
34	3"1/2	GFC114	120,65	152	69,85	136	22	M16	5/8"	3,00
34	4"	GFC116	130,18	162	77,77	146	25	M16	5/8"	3,98
34	5"	GFC118	152,40	190	92,08	170	28	M16	5/8"	4,10

SERIE 6000

414	1/2"	GFC401	40,49	56	18,24	48	16	M8	5/16"	0,25
414	3/4"	GFC402	50,80	71	23,80	60	19	M10	3/8"	0,46
414	1"	GFC403	57,15	81	27,76	70	24	M12	7/16"	0,84
414	1"1/4	GFC404	66,68	95	31,75	78	27	M14	1/2"	1,24
414	1"1/2	GFC405	79,38	112	36,50	94	30	M16	5/8"	1,89
414	2"	GFC406	96,82	134	44,45	114	30	M20	3/4"	2,69
414	2"1/2	GFC507	123,80	180	58,70	152	45	M24	7/8"	7,50
414	3"	GFC508	152,40	208	71,40	178	55	M30	1"1/8	12,4

DESIGNAZIONE PER ORDINE DESIGNATION FOR ORDER	Materiale / Material	
	S355	AISI 316L
Controflangia con fori di fissaggio filettati metrici Counter-flange with metric threaded fixing holes	GFC...	GFCX...
Controflangia con fori di fissaggio filettati unc Counter-flange with unc threaded fixing holes	GFC...U	GFCX...U