

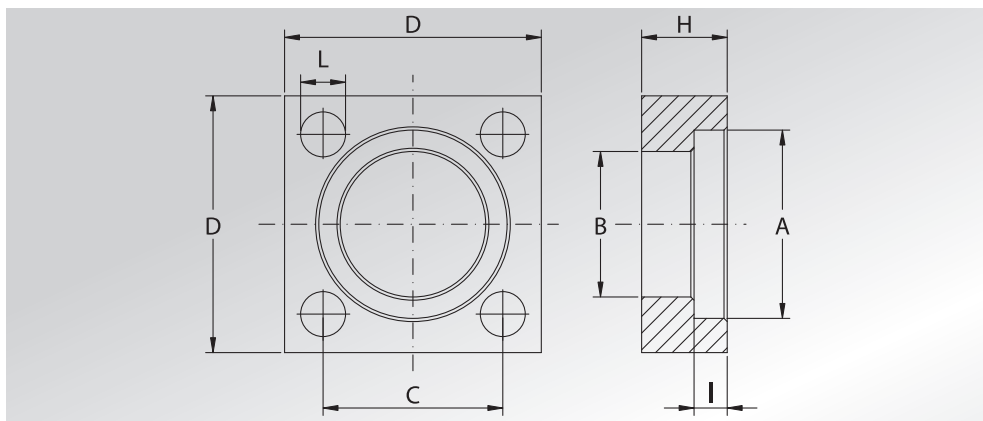

FLANGE QUADRE ISO 6164

SQUARE FLANGES ISO 6164



Pressione max di esercizio raccomandata Bar	Grandezza	Tipo	Dimensioni							Peso Kg
Maximum recommended working pressure Bar	Size	Type	Dimensions							Weight Kg
			A	B	C	D	H	I	L	

SERIE 250

250	1"	Q1ST250	45,3	38,50	43,8	65	25	7,5	11	0,50
250	1"1/4	Q114ST250	51,6	43,70	51,6	75	30	7,5	13	0,81
250	1"1/2	Q112ST250	61,1	50,80	60,1	90	36	7,5	17	1,40
250	2"	Q2ST250	72,3	62,80	69,4	100	40	9	17	1,80
250	2"1/2	Q212ST250	88,0	76,60	83,4	120	45	9	21	2,85
250	3"	Q3ST250	102,3	90,80	102,5	140	52	9	21	4,65
250	4"	Q4ST250	132,0	114,50	113,2	160	60	21	25	5,70

SERIE 400

400	1"	Q1ST400	48,4	38,90	43,8	65	25	9	11	0,47
400	1"1/4	Q114ST400	54,8	44,60	51,6	75	30	9,8	13	0,76
400	1"1/2	Q112ST400	64,3	51,60	60,1	90	36	12	17,5	1,30
400	2"	Q2ST400	80,2	67,60	69,4	100	40	12,2	17	1,60
400	2"1/2	Q212ST400	95,0	80,50	83,4	120	50	16,1	21	2,90
400	3"	Q3ST400	105,0	90,50	102,5	150	52	16,1	26	5,40
400	4"	Q4ST400	132,0	114,50	123,7	180	70	21,0	33	9,68

DESIGNAZIONE PER ORDINE DESIGNATION FOR ORDER	Materiale / Material	
	S355	AISI 316L
Solo flangia Only flange	Q...ST...	QX...ST