

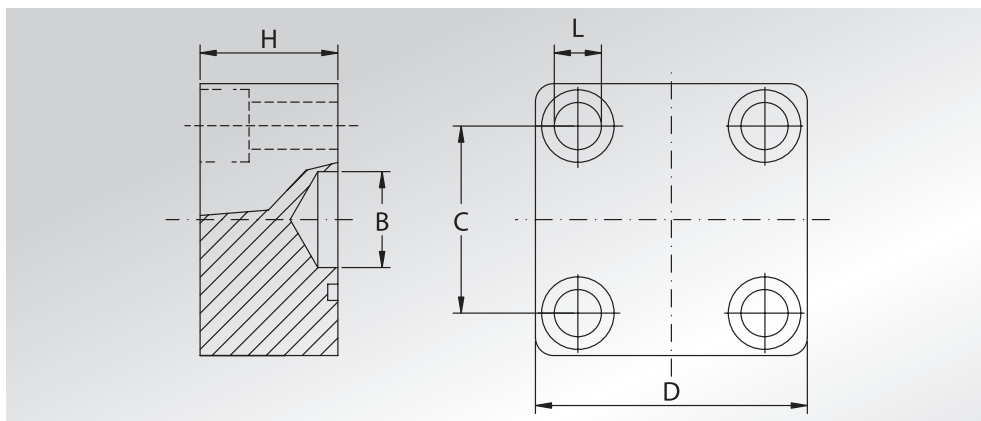

# FLANGE CETOP CIECHE

## BLIND CETOP FLANGES



Pressione max di esercizio raccomandata Bar	Grandezza	Tipo	Dimensioni					Viti	Or tipo	Peso Kg
Maximum recommended working pressure Bar	Size	Type	Dimensions					Screws	Or type	Weight Kg
			B	C	D	H	L	Metric		

### SERIE 250

250	1/2"	CET12C250	14	29,7	45	32	8,5	M8x45	4075	0,41
250	3/4"	CET34C250	19	35,3	50	32	8,5	M8x45	4100	0,49
250	1"	CET1C250	25	43,8	65	35	11	M10x50	4131	0,93
250	1 1/4"	CET114C250	30	51,6	75	38	13	M12x55	4150	1,32
250	1 1/2"	CET112C250	36	60,0	85	42	15	M14x65	4187	1,88
250	2"	CET2C250	45	69,4	100	44	17	M16x70	4225	2,72
250	2 1/2"	CET212C250	58	83,4	120	55	21	M20x70	4275	4,83
250	3"	CET3C250	60	102,5	140	60	21	M20x70	4337	7,72
250	4"	CET4C250	70	113,2	160	60	25	M24x80	4387	9,80
250	4"	CET4C250 OR6387	70	113,2	160	60	25	M24x80	6787	9,75

### SERIE 400

400	1/2"	CET12C400	14	29,7	45	32	8,5	M8x45	4075	0,41
400	3/4"	CET34C400	19	35,3	50	32	8,5	M8x45	4100	0,49
400	1"	CET1C400	25	43,8	65	35	11	M10x50	4131	0,93
400	1 1/4"	CET114C400	30	51,6	75	38	13	M12x55	4150	1,32
400	1 1/2"	CET112C400	36	60,0	85	42	15	M14x65	4187	1,88
400	2"	CET2C400	45	69,4	100	44	17	M16x70	4225	2,72
400	2 1/2"	CET212C400	58	83,4	120	55	21	M20x70	4275	4,83
400	2 1/2"	CET212C400 OR6275	58	83,4	120	55	21	M20x70	6275	4,80
400	3"	CET3C400	60	102,5	140	60	21	M20x70	4275	7,72
400	3"	CET3C400 OR6300	60	102,5	140	60	21	M20x70	6300	7,68
400	4"	CET4C400	70	113,2	160	60	25	M24x80	4337	9,80
400	4"	CET4C400 OR6350	70	113,2	160	60	25	M24x80	6350	9,76

DESIGNAZIONE PER ORDINE DESIGNATION FOR ORDER	Materiale / Material	
	S355	AISI316L

Solo flangia Only flange	<b>CET...C..</b>	<b>CETX...C..</b>
-----------------------------	------------------	-------------------

--	--	--

--	--	--