

**FLANGE  
A SALDARE  
DI TASCA  
TUBO METRICO**

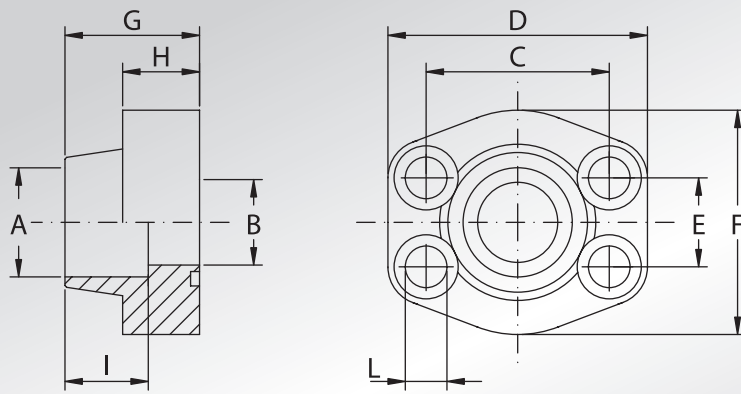

**METRIC PIPE  
WELD IN  
FLANGES**



Pressione max di esercizio raccomandata Kg/cm <sup>2</sup>	Grandezza	Tipo	Dimensioni										Viti		Or tipo	Peso Kg
Maximum recommended working pressure Kg/cm <sup>2</sup>	Size	Type	Dimensions										Screws		Or type	Weight Kg
			A	B	C	D	E	F	G	H	I	L	Metric	Unc		

**SERIE 3000**

345	1/2"	AFS080SA20	20,3	13	38,10	57	17,48	46	36	16	19	9	M8x30	5/16"x1"1/4	4075	0,25
345	3/4"	AFS100SA25	25,3	19	47,63	65	22,23	50	36	18	19	11	M10x35	3/8"x1"1/2	4100	0,39
345	1"	AFS102SA30	30,3	25	52,37	70	26,19	55	38	18	19	11	M10x35	3/8"x1"1/2	4131	0,46
276	1"1/4	AFS104SA38	38,3	32	58,72	79	30,18	68	41	21	22	11,5	M10x40	7/16"x1"3/4	4150	0,66
207	1"1/2	AFS106SA50	50,5	38	69,85	93	35,71	78	45	25	24	13,5	M12x45	1/2"x1"3/4	4187	1,05

**SERIE 6000**

414	1/2"	AFS401SA20	20,3	13	40,49	57	18,24	46	36	16	19	9	M8x30	5/16"x1"1/4	4075	0,25
414	3/4"	AFS402SA25	25,3	19	50,80	71	23,80	55	35	21	22	11	M10x40	3/8"x1"1/2	4100	0,50
414	1"	AFS403SA30	30,3	25	57,15	81	27,76	65	42	25	22	13	M12x45	7/16"x1"3/4	4131	0,76
414	1"1/4	AFS404SA38	38,3	32	66,68	95	31,75	78	45	27	25	15	M14x45	-	4150	1,20
414	1"1/4	AFS404SA38L13	38,3	32	66,68	95	31,75	78	45	27	25	13,5	M12x45	1/2"x1"3/4	4150	1,20
414	1"1/2	AFS405SA50	50,5	38	79,38	112	36,50	94	50	30	28	17	M16x55	5/8"x2"1/4	4187	1,90

DESIGNAZIONE PER ORDINE DESIGNATION FOR ORDER	Materiale / Material	
	S355	AISI 316L
Solo flangia Only flange	<b>AFS...SA</b>	<b>AFX...SA</b>
Flangia completa di viti metriche, grower e o-ring Flange complete of metric screws, grower type washers and o-ring	<b>AFS...SMA</b>	<b>AFX...SMA</b>
Flangia completa di viti unc, grower e o-ring Flange complete of unc screws, grower type washers and o-ring	<b>AFS...SUA</b>	<b>AFX...SUA</b>

**NOTE / NOTES**

set viti unc disponibili solo in acciaio al carbonio  
unc screws set available only in carbon steel