

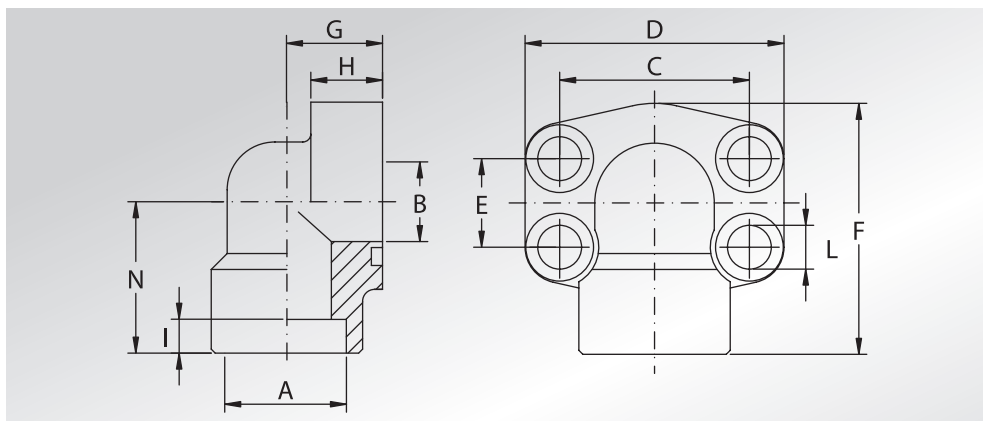

FLANGE A 90° A SALDARE DI TASCA TUBO METRICO

METRIC PIPE WELD IN 90° FLANGES



Pressione max di esercizio raccomandata Kg/cm ²	Grandezza	Tipo	Dimensioni											Viti		Or tipo	Peso Kg
Maximum recommended working pressure Kg/cm ²	Size	Type	Dimensions											Screws		Or type	Weight Kg
			A	B	C	D	E	F	G	H	I	L	N	Metric	Unc		

SERIE 3000

345	1/2"	AFS08090SA20	20,3	13	38,10	54	17,48	60	20	16	10	9	37	M8x30	5/16"x1"1/4	4075	0,28
345	3/4"	AFS10090SA25	25,3	19	47,63	65	22,23	63	24	18	10	11	38	M10x35	3/8"x1"1/2	4100	0,45
345	1"	AFS10290SA30	30,3	25	52,37	70	26,19	70	28	19	12	11	43	M10x35	3/8"x1"1/2	4131	0,56
276	1"1/4	AFS10490SA38	38,3	32	58,72	79	30,18	85	34	21	14	11,5	51	M10x40	7/16"x1"3/4	4150	0,89
207	1"1/2	AFS10690SA50	50,5	38	69,85	93	35,71	95	38	25	16	13,5	56	M12x45	1/2"x1"3/4	4187	1,18

SERIE 6000

414	1/2"	AFS40190SA20	20,3	13	40,49	54	18,24	60	20	16	10	9	37	M8x30	5/16"x1"1/4	4075	0,28
414	3/4"	AFS40290SA25	25,3	19	50,80	70	23,80	70	28	19	12	11	43	M10x40	3/8"x1"1/2	4100	0,69
414	1"	AFS40390SA30	30,3	25	57,15	79	27,76	85	34	21	14	13	51	M12x45	7/16"x1"3/4	4131	1,11
414	1"1/4	AFS40490SA38	38,3	32	66,68	93	31,75	95	38	25	16	15	56	M14x45	-	4150	1,45
414	1"1/4	AFS40490SA38L13	38,3	32	66,68	93	31,75	95	38	25	16	13,5	56	M12x45	1/2"x1"3/4	4150	1,45
414	1"1/2	AFS40590SA50	50,5	38	79,38	110	36,50	110	42	25	18	17	65	M16x55	5/8"x2"1/4	4187	2,75

DESIGNAZIONE PER ORDINE DESIGNATION FOR ORDER	Materiale / Material	
	S355	AISI 316L
Solo flangia Only flange	AFS...90SA	AFX...90SA
Flangia completa di viti metriche, grower e o-ring Flange complete of metric screws, grower type washers and o-ring	AFS...90SA...M	AFX...90SA...M
Flangia completa di viti unc, grower e o-ring Flange complete of unc screws, grower type washers and o-ring	AFS...90SA...U	AFX...90SA...U

NOTE / NOTES

set viti unc disponibili solo in acciaio al carbonio
unc screws set available only in carbon steel