

**CONTROFLANGE
A 90° A SALDARE
DI TASCA**

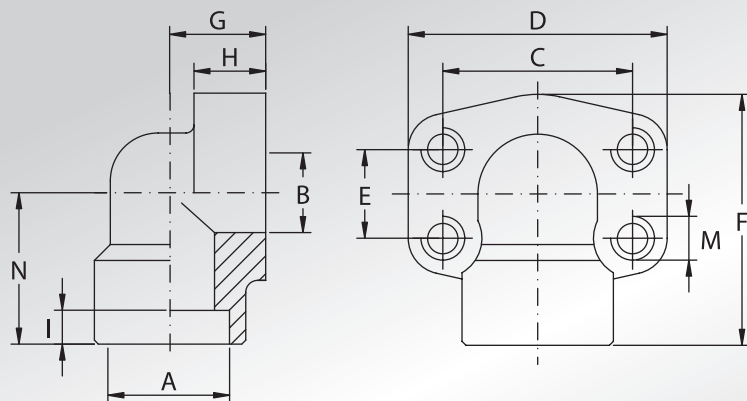

**WELD IN 90°
COUNTER-FLANGES**



Pressione max di esercizio raccomandata Kg/cm ²	Grandezza	Tipo	Dimensioni											Peso Kg	
			Dimensions												
Maximum recommended working pressure Kg/cm ²	Size	Type	A	B	C	D	E	F	G	H	I	N	M	Weight Kg	
SERIE 3000															
345	1/2"	GFS08090S	21,6	13	38,10	54	17,48	60	20	16	10	37	M8	5/16"	0,28
345	1/2"	GFS08090S038	17,5	13	38,10	54	17,48	60	20	16	10	37	M8	5/16"	0,29
345	3/4"	GFS10090S	27,2	19	47,63	65	22,23	63	24	18	10	38	M10	3/8"	0,45
345	1"	GFS10290S	34,0	25	52,37	70	26,19	70	28	19	12	43	M10	3/8"	0,56
276	1"1/4	GFS10490S	42,8	32	58,72	79	30,18	85	34	21	14	51	M10	7/16"	0,89
207	1"1/2	GFS10690S	48,6	38	69,85	93	35,71	95	38	25	16	56	M12	1/2"	1,18
207	2"	GFS10890S	61,0	51	77,77	110	42,88	110	42	25	18	65	M12	1/2"	2,06
SERIE 6000															
414	1/2"	GFS40190S012	21,6	13	40,49	54	18,24	60	20	16	10	37	M8	5/16"	0,28
414	1/2"	GFS40190S038	17,5	13	40,49	54	18,24	60	20	16	10	37	M8	5/16"	0,29
414	3/4"	GFS40290S	27,2	19	50,80	70	23,80	70	28	19	12	43	M10	3/8"	0,69
414	1"	GFS40390S	34,0	25	57,15	79	27,76	85	34	21	14	51	M12	7/16"	1,11
414	1"1/4	GFS40490S	42,8	32	66,68	93	31,75	95	38	25	16	56	M14	1/2"	1,45
414	1"1/2	GFS40590S	48,6	38	79,38	110	36,50	110	42	25	18	65	M16	5/8"	2,75
414	2"	GFS40690S	61,0	51	96,82	134	44,45	132	45	35	25	75	M20	3/4"	3,85

DESIGNAZIONE PER ORDINE DESIGNATION FOR ORDER	Materiale / Material	
	S355	AISI 316L
Controflangia con fori di fissaggio filettati metrici Counter-flange with metric threaded fixing holes	GFS...90S	GFX...90S
Controflangia con fori di fissaggio filettati UNC Counter-flange with UNC threaded fixing holes	GFS...90SU	GFX...90SU