

CONTROFLANGE A SALDARE DI TESTA SCH.XXS

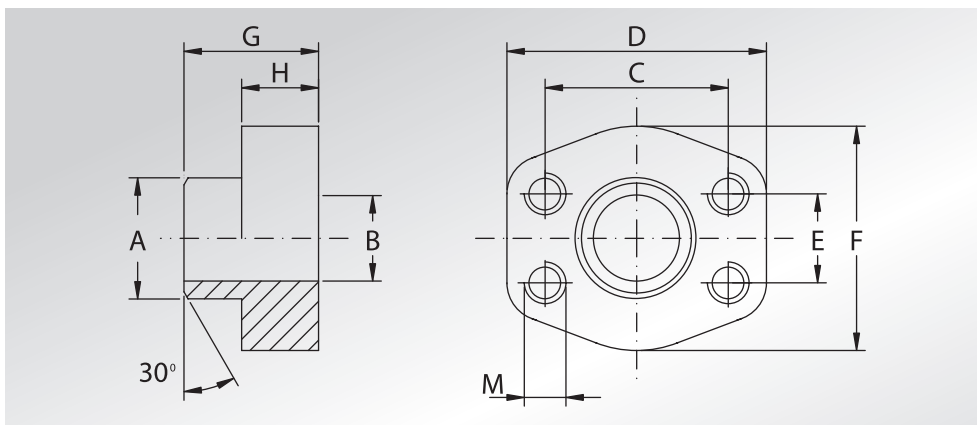

WELD ON COUNTER-FLANGES SCH.XXS



Pressione max di esercizio raccomandata Kg/cm ²	Grandezza	Tipo	Dimensioni									Peso Kg
Maximum recommended working pressure Kg/cm ²	Size	Type	Dimensions									Weight Kg
			A	B	C	D	E	F	G	H	M	

SERIE 3000

											Metric	Unc	
345	1/2"	GFS080STB6	21,5	6,3	38,10	57	17,48	46	36	16	M8	5/16"	0,25
345	3/4"	GFS100STB11	28,0	11,0	47,63	65	22,23	50	36	18	M10	3/8"	0,39
345	1"	GFS102STB15	34,0	15,2	52,37	70	26,19	55	38	18	M10	3/8"	0,45
276	1"1/4	GFS104STB22	42,8	22,8	58,72	79	30,18	68	41	21	M10	7/16"	0,69
207	1"1/2	GFS106STB28	48,6	28,0	69,85	93	35,71	78	44	25	M12	1/2"	1,05
207	2"	GFS108STB38	61,0	38,2	77,77	102	42,88	90	45	25	M12	1/2"	1,22
172	2"1/2	GFS110STB45	77,0	45,0	88,90	114	50,80	105	50	25	M12	1/2"	1,63
138	3"	GFS112STB58	92,0	58,4	106,38	134	61,93	124	50	27	M16	5/8"	2,42
138	4"	GFS116STB80	115,5	80,0	130,18	162	77,77	146	48	27	M16	5/8"	2,94
138	5"	GFS118STB102	140,2	102,9	152,40	184	92,08	180	50	28	M16	5/8"	5,00

SERIE 6000

414	1/2"	GFS401ST012B6	21,5	6,3	40,49	57	18,24	46	36	16	M8	5/16"	0,25
414	3/4"	GFS402STB11	28,0	11,0	50,80	71	23,80	55	35	21	M10	3/8"	0,52
414	1"	GFS403STB15	34,0	15,2	57,15	79	27,76	68	42	25	M12	7/16"	0,70
414	1"1/4	GFS404STB22	42,8	22,8	66,68	93	31,75	78	44	25	M14	1/2"	1,08
414	1"1/2	GFS405STB28	48,6	28,0	79,38	112	36,50	94	55	28	M16	5/8"	1,76
414	2"	GFS406STB38	61,0	38,2	96,82	134	44,45	114	65	37	M20	3/4"	2,98
414	2"1/2	GFS507STB45	76,6	45,0	123,80	180	58,70	152	80	45	M24	7/8"	7,90
414	3"	GFS508STB58	90,0	58,4	152,40	208	71,40	178	90	55	M30	1"1/8"	12,45

PER QUESTA TIPOLOGIA DI PRODOTTO, VERIFICATE SEMPRE SE LA QUOTA "A" E "B" CORRISPONDE ALLA SCHEDULA DEL VOSTRO TUBO

FOR THIS KIND OF PRODUCT, PLEASE ALWAYS VERIFY IF DIMENSION "A" AND "B" CORRESPOND TO THE SCHEDULE OF YOUR TUBE

DESIGNAZIONE PER ORDINE DESIGNATION FOR ORDER	Materiale / Material	
	S355	AISI 316L
Controflangia con fori di fissaggio filettati metrici Counter-flange with metric threaded fixing holes	GFS...STB	GFX...STB
Controflangia con fori di fissaggio filettati unc 8 Counter-flange with unc threaded fixing holes	GFS...STB...U	GFX...STB...U