

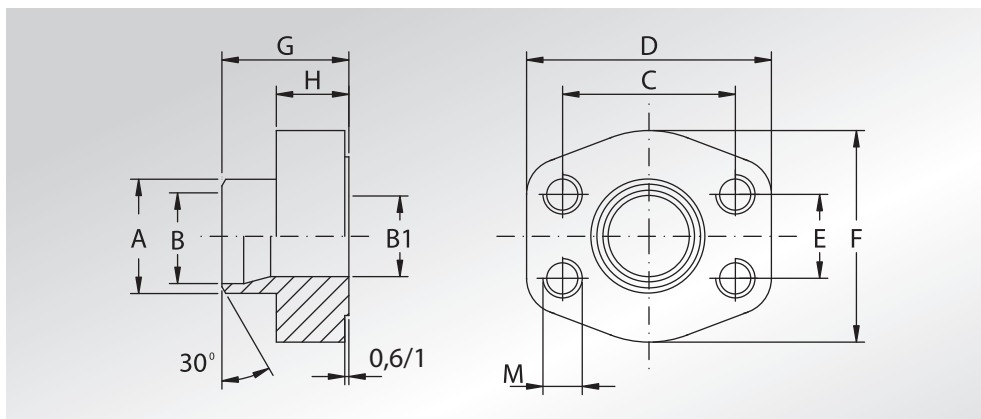

# CONTROFLANGE A SALDARE DI TESTA TUBO METRICO

## METRIC PIPE WELD ON COUNTER-FLANGES



Pressione max di esercizio raccomandata Kg/cm <sup>2</sup>	Grandezza	Tipo	Dimensioni											Peso Kg	
Maximum recommended working pressure Kg/cm <sup>2</sup>	Size	Type	Dimensions											Weight Kg	
			A	B	B1	C	D	E	F	G	H	M			
<b>SERIE 3000</b>													<b>Metric</b>	<b>Unc</b>	
345	1/2"	GFS080SRE20	20	14	13	38,10	57	17,48	46	35	16	M8	5/16"	0,25	
345	1/2"	GFS080SRE22	22	16	13	38,10	57	17,48	46	35	16	M8	5/16"	0,25	
345	3/4"	GFS100SRE28	28	21,5	19	47,63	65	22,23	50	36	18	M10	3/8"	0,39	
345	1"	GFS102SRE35	35	27	25	52,37	70	26,19	55	38	18	M10	3/8"	0,45	
276	1"1/4	GFS104SRE42	43	36	31	58,72	79	30,18	68	41	21	M10	7/16"	0,69	
207	1"1/2	GFS106STRE48	49	42	38	69,85	93	35,71	78	44,5	24,5	M12	1/2"	1,05	
207	2"	GFS108STRE60	61	53	49	77,77	102	42,88	90	45	25	M12	1/2"	1,22	
172	2"1/2	GFS110STRE76	77	70	62	88,90	114	50,80	105	50	25	M12	1/2"	1,63	
138	3"	GFS112STRE88	90	82	74	106,38	134	61,93	124	51	26	M16	5/8"	2,42	
34	4"	GFS116STRE114	115	107	102	130,18	162	77,77	146	48	26	M16	5/8"	2,94	
34	5"	GFS118STREH139	140,2	131	120	152,40	184	92,08	180	50	28	M16	5/8"	4,00	
<b>SERIE 6000</b>															
414	1"1/2	GFS405SRE60	61	40	38	79,38	112	36,50	94	56	28	M16	5/16"	1,76	

DESIGNAZIONE PER ORDINE DESIGNATION FOR ORDER	Materiale / Material	
	S355	AISI 316L
Controflangia con fori di fissaggio filettati metrici Counter-flange with metric threaded fixing holes	<b>GFS...SRE / STRE</b>	<b>GFX...SRE / STRE</b>
Controflangia con fori di fissaggio filettati unc Counter-flange with unc threaded fixing holes	<b>GFS...SREU / STREU</b>	<b>GFX...SREU / STREU</b>